



Product Features

- 5 ~ 1000MHz
- 8 ~ 12V Supply Voltage
- Lower manufacturing cost
- -69dBc CSO 79 Channels @ 43dBmV
- -64dBc CTB 79 Channels @ 43dBmV
- -60dBc XMOD 79 Channels @ 43dBmV

Applications

- Cable Modem
- FTTH (G-PON, GE-PON)
- Optical node
- Low Noise Amplifier for CATV, Satellite



Package Type : SOIC-8

Description

AE618 is designed as low cost drive amplifiers for many applications including FTTH, CATV System. This MMIC is based on Gallium Arsenide Enhancement Mode pHEMT which shows low current draw and very low noise. The data in this spec sheet is valid only for 75ohm application. 50ohm data is in a separate spec sheet.

Electrical Specifications

PARAMETER	UNIT	MIN	TYP	MAX	CONDITION	
Operating Frequency	MHz	30	-	1000	-	
Gain	dB	18	20	-	30 ~ 1000MHz	
Gain Flatness	dB	-	0.7	1.5	30 ~ 1000MHz	
Input Return Loss	dB	-	-12	-	-	
Output Return Loss	dB	-	-15	-	-	
Output IP3	dBm	39	44	-	@ 500MHz/10dBm 2tone	
1dB Compression Point	dBm	28	32	-	@ 500MHz	
Noise Figure	dB	-	2.5	3.5	30 ~ 1000MHz	
CSO	30 ~ 1004MHz	dBc	-	-69	-	79 channel, Flat, 43dBmV Vdd = 12V
CTB		dBc	-	-64	-	
XMOD		dBc	-	-60	-	
DC Current	mA	-	410	-	Vdd = 8V	
		-	360	-	Vdd = 12V	

Note

1. Test conditions unless otherwise noted. Test Freq = 500MHz, T=25 °C, Vdd=12V, 75Ω system
2. OIP3 measured with 2 tones at an output power of 10dBm/tone separated by 1MHz, Test Freq = 500MHz

Absolute Maximum Ratings

PARAMETER	UNIT	MIN	TYP	MAX
Device Voltage	VDC	-	-	14
Current	mA	-	-	650
Operating Temperature	°C	-40	-	85
Storage Temperature	°C	-40	-	150
ESD Human Body Model	-	-	Class 1B	-
Moisture Sensitivity Level	-	-	MSL1	-
Junction Temperature (Tj)	°C	-	-	180

Thermal Resistance (Rth)	°C/W	-	10.7	-
--------------------------	------	---	------	---

Application Circuit @ 30 ~ 1000MHz, 75ohm System, VDD=12V

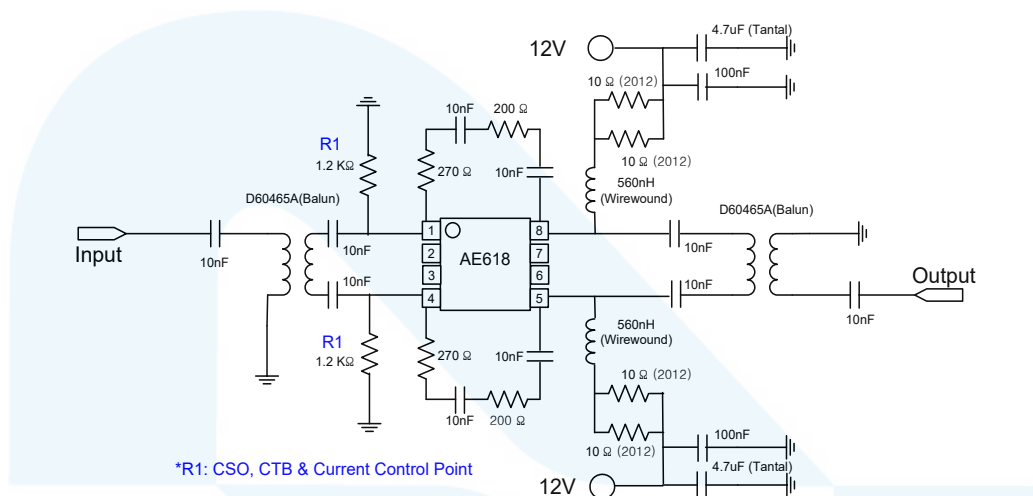

Typical Performance @ VDD=12V, IDS=360mA, T=25°C, 75ohm System

Frequency	MHz	30	500	1000
Gain(S21)	dB	20.2	20.2	20.7
Input Return Loss(S11)	dB	-18.4	-13	-11
Output Return Loss(S22)	dB	-20	-14	-20
Output IP3	dBm	44	44	41
1dB Compression Point	dBm	32	32	29
Noise Figure	dB	1.9	2.2	2.6
CSO*	dBc		-69	
CTB*	dBc		-64	
XMOD*	dBc		-60	
Current	mA		360	

* 79channels_Flat, +43dBmV

Frequency vs. Gain

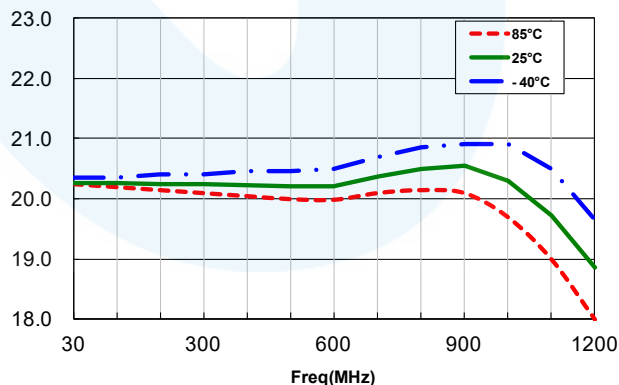

Frequency vs. S11

Frequency vs. S22

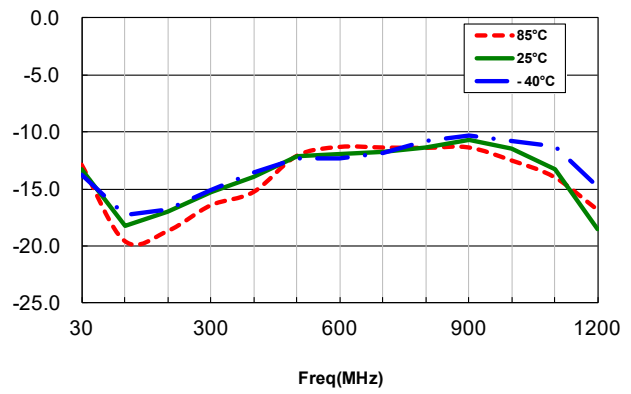
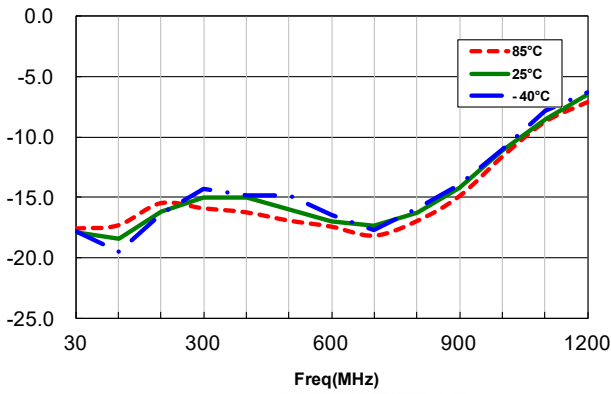

Frequency vs. OIP3

Frequency vs. P1dB

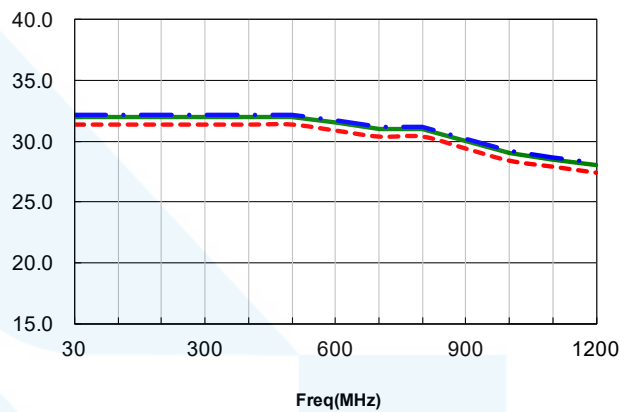
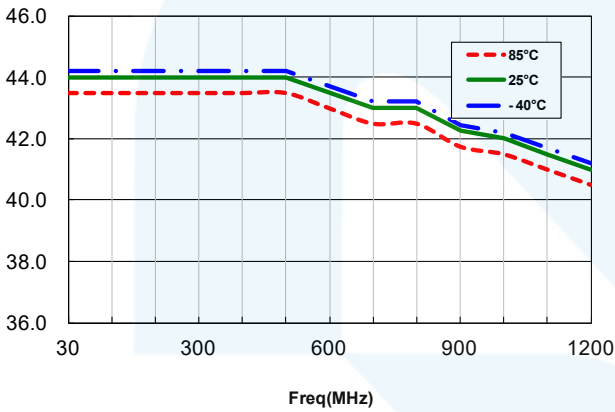

Application Circuit @ 5 ~ 200MHz, 75ohm System, VDD=12V

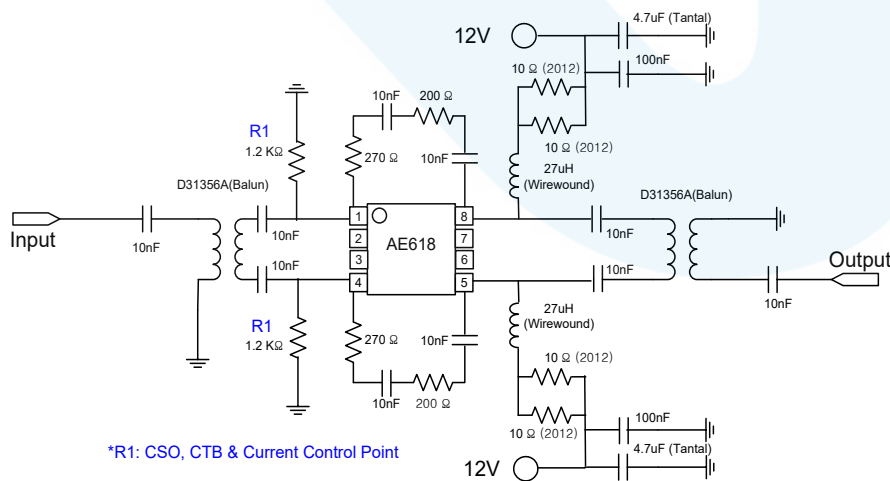

Typical Performance @ VDD=12V, IDS=360mA, T=25°C, 75ohm System

PARAMETER	UNIT	TYPICAL		
Frequency	MHz	5	100	200
Gain(S21)	dB	20.7	20.6	20.4
Input Return loss(S11)	dB	-29	-31	-19
Output Return loss(S22)	dB	-24	-36	-19
Output IP3	dBm	43	45	44
1dB Compression Point	dBm	32	32	31
Noise Figure	dB	2.0	2.4	2.8

S-Parameter

All specifications may change without notice

Version 1.4

* 8channels_Flat, +47dBmV

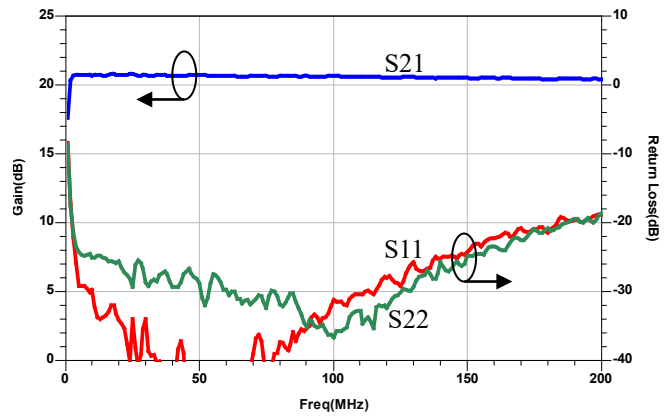

Frequency vs. OIP3

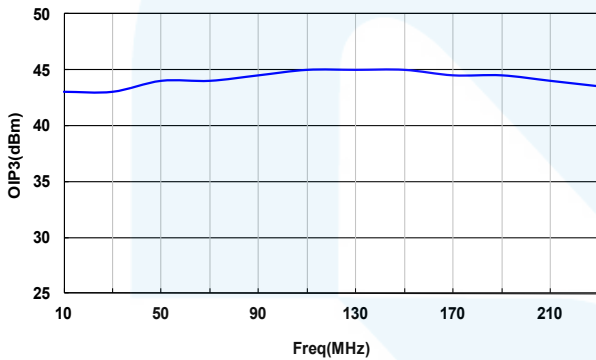

Frequency vs. P1dB

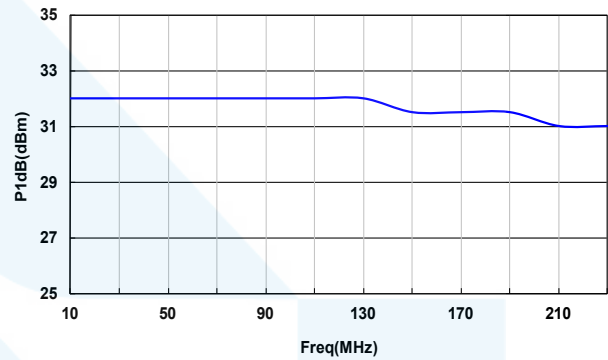

Application Circuit @ 30 ~ 1000MHz, 75ohm System, VDD=8V

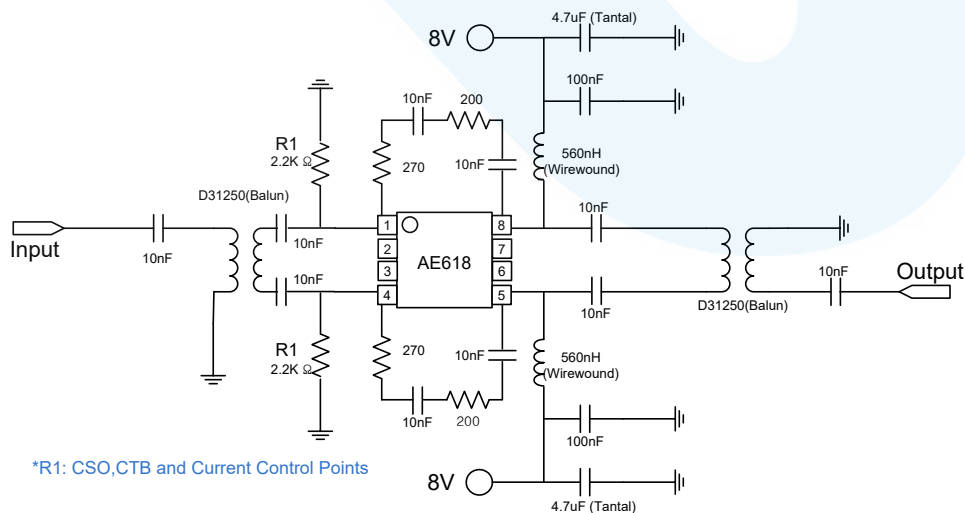

Typical Performance @ VDD=8V, IDS=410mA, T=25°C, 75ohm System

PARAMETER	UNIT	TYPICAL		
Frequency	MHz	30	500	1000
Gain(S21)	dB	20.5	20.6	19.8
Input Return loss(S11)	dB	-13	-13	-11
Output Return loss(S22)	dB	-19	-14	-16
Output IP3	dBm	44	43	39
1dB Compression Point	dBm	31	31	27

S-Parameter

All specifications may change without notice

Version 1.4

* 79channels_Flat, +43dBmV

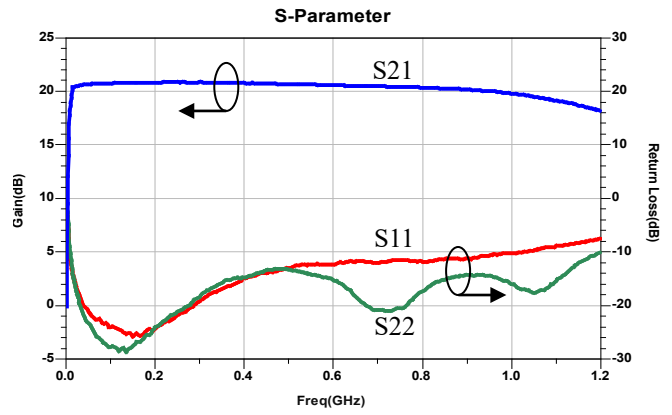

Package Dimensions (Type: SOIC-8)

* Unit: mm[inch] | Tolerance ± 0.2 [.008]

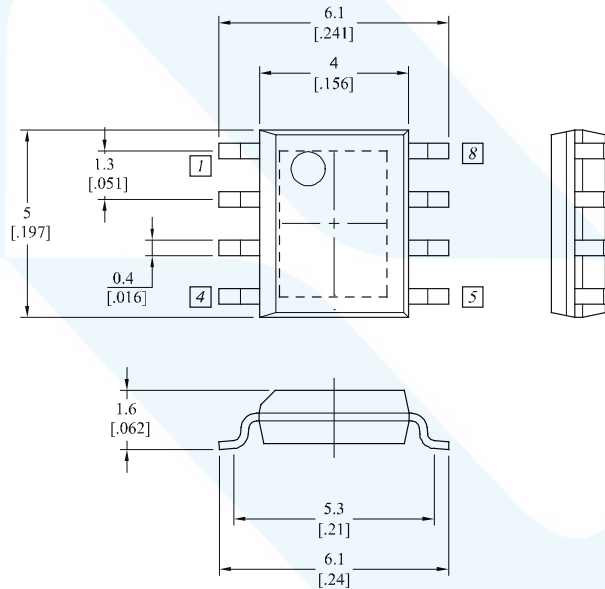

Pin Description			
Pin No	Function	Pin No	Function
1	RF IN(2)	5	RF OUT(1)
2	GND	6	GND
3	GND	7	GND
4	RF IN(1)	8	RF OUT(2)

Recommended Pattern

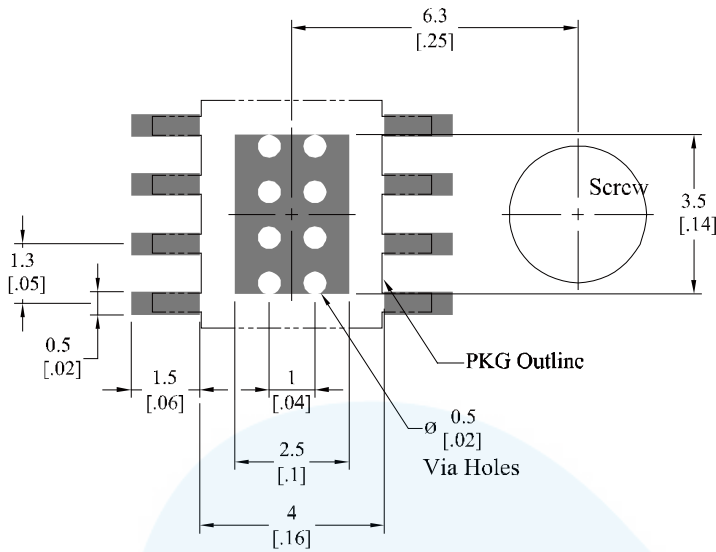

Mounting Configuration Notes

1. Ground / thermal via holes are critical for the proper performance of this device.
2. Add as much copper as possible to inner and outer layers near the part to ensure optimal thermal performance.
3. Mounting screws can be added near the part to fasten the board to a heat sink. Ensure that the ground / thermal via hole region contacts the heat sink.
4. Do not put solder mask on the backside of the PCB in the region where the board contacts the heat sink.
5. RF trace width depends upon the PCB material and construction.
6. Use 1 oz. Copper minimum.

Revision History

Part Number	Release Date	Version	Modification	Data Sheet Status
AE618	2014.04.18	1.4	Thermal Resistance (1p)	-
AE618	2013.12.13	1.3	5~200MHz Application Circuit	-
AE618	2013.07.25	1.2	Vdd=8V Application Circuit	-



Certification

This product is manufactured by a company that is certified for the AS9100D quality management system.

RFHIC Corporation reserves the right to make changes to any products herein or to discontinue any product at any time without notice. While product specifications have been thoroughly examined for reliability, RFHIC Corporation strongly recommends buyers to verify that the information they are using is accurate before ordering. RFHIC Corporation does not assume any liability for the suitability of its products for any particular purpose, and disclaims any and all liability, including without limitation consequential or incidental damages. RFHIC products are not intended for use in life support equipment or application where malfunction of the product can be expected to result in personal injury or death. Buyer uses or sells such products for any such unintended or unauthorized application, buyer shall indemnify, protect, and hold RFHIC Corporation and its directors, officers, stockholders, employees, representatives and distributors harmless against any and all claims arising out of such unauthorized use. All sales inquiries and support should be directed to the local authorized geographic distributor for RFHIC Corporation. For customers in the US, please contact the US sales team through our website at <https://rfhic.com/rfhic-us/>. For all other inquiries, please contact our international sales team through our website portal at <https://rfhic.com/contact/>