

Product Features

- 758~858MHz
- 220W Saturated Power @ 48V
- 75% Drain Efficiency @ Psat
- 38% Drain Efficiency @ 47dBm
- Internally Matched

Applications

- WiMAX, LTE, WCDMA, GSM
- Multi-Band, Multi-Mode
- Multi-Carrier
- High Efficiency, Doherty Amplifier

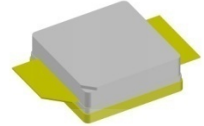

Package Type : NS-AS01

Typical Single-Carrier LTE Performance ($V_{DS} = +48V$, $T_C = 25^\circ C$, 50Ω)

Frequency [MHz]	Peak Power		Average Power ^{*1}			
	Power [W]	Drain Efficiency [%]	Power [W]	Gain [dB]	Drain Efficiency [%]	ACLR [dBc]
763.0	254.7	75.8	50	21.3	38.8	-29.3
808.0	271.0	77.6	50	22.0	38.9	-29.4
853.0	243.8	77.4	50	20.9	40.0	-28.7

Note

*1 Measured in the IE08220P test board amplifier circuit, under LTE 10MHz, PAR 7.5dB @0.01% probability on CCDF

Absolute Maximum Ratings

Rating	Symbol	Value	Unit	Condition
Drain to Source Voltage	V_{DSS}	150	V	$T_C = 25^\circ C$
Gate to Source Voltage	V_{GS}	-10, +2	V	$T_C = 25^\circ C$
Operating Voltage	V_{DD}	52	V_{DC}	-
Maximum Forward Gate Current	I_{GMAX}	32	mA	$T_C = 25^\circ C$
Maximum Drain Current ^{*1}	I_{DMAX}	12	A	$T_C = 25^\circ C$
Power Dissipation	P_{DISS}	105	W	$T_C = 85^\circ C$
Storage Temperature	T_{STG}	-65, +150	$^\circ C$	-
Case Operating Temperature	T_C	-40, +150	$^\circ C$	30 seconds
Operating Junction Temperature ^{*2}	T_J	225	$^\circ C$	-
Soldering Temperature ^{*3}	T_S	245	$^\circ C$	-

Note

*1 Current Limit for long term, reliable operation.

*2 Continuous use at maximum temperature will affect MTTF.

*3 Refer to the Application Note(AN-002) on soldering - "Solder Condition for RFHIC's GaN Device"

Thermal Characteristics

Rating	Symbol	Value	Unit	Condition
Thermal Resistance, Junction to Case	$R_{\theta JC}$	1.33	$^\circ C/W$	$T_C = 85^\circ C$

Note

*1 Measured for the IE08220P at dissipation power is 105.1W.

Electrical Characteristics ($T_C=25^\circ\text{C}$ unless otherwise noted)

Characteristics	Conditions	Symbol	Min	Typ	Max	Unit
DC Characteristics ^{*1}						
Gate Threshold Voltage	$V_{DS} = 10\text{V}$	$V_{GS(TH)}$	-3.8	-3.0	-2.3	V_{DC}
	$I_D = 28.8\text{mA}$					
Gate Quiescent Voltage	$V_{DS} = 48\text{V}$	$V_{GS(Q)}$	-	-2.8	-	V_{DC}
	$I_D = 1000\text{mA}$					
Saturated Drain Current ^{*2}	$V_{DS} = 6\text{V}$	I_{DS}	24.0	28.8	-	A
	$V_{GS} = 2\text{V}$					
Drain-Source Breakdown Voltage	$V_{GS} = -8\text{V}$	V_{BR}	150	-	-	V
	$I_D = 28.8\text{mA}$					
Gate Leakage Current	$V_{GS} = -8\text{V}$	I_{GLKG}	-6.3	-	-	mA
	$V_{DS} = 120\text{V}$					
Drain Leakage Current	$V_{GS} = -8\text{V}$	I_{DLKG}	-	-	11.5	mA
	$V_{DS} = 120\text{V}$					
RF Characteristics ($F_c=808\text{MHz}$ unless otherwise noted)						
Saturated Output Power ^{*3,6}	$V_{DS} = 48\text{V}$	P_{SAT}	-	220	-	W
	$I_{DQ} = 1000\text{mA}$					
Pulsed Drain Efficiency ^{*3}	$V_{DS} = 48\text{V}$	η	70.0	75.0	-	%
	$I_{DQ} = 1000\text{mA}$					
	$P_{OUT} = P_{SAT}$ Pulsed					
Modulated Gain ^{*4}	$V_{DS} = 48\text{V}$	G_{BR}	17.0	20.0	-	dB
	$I_{DQ} = 1000\text{mA}$					
	$P_{OUT} = 47\text{dBm}$					
LTE Linearity ^{*4}	$V_{DS} = 48\text{V}$	ACLR	-	-29.0	-26.0	dBc
	$I_{DQ} = 1000\text{mA}$					
	$P_{OUT} = 47\text{dBm}$					
Modulated Drain Efficiency ^{*4}	$V_{DS} = 48\text{V}$	η	34.0	38.0	-	%
	$I_{DQ} = 1000\text{mA}$					
	$P_{OUT} = 47\text{dBm}$					
Output Mismatch Stress ^{*3,5}	$V_{DS} = 48\text{V}$	VSWR	-	-	10:1	ψ
	$I_{DQ} = 1000\text{mA}$					
	$P_{OUT} = P_{SAT}$ Pulsed					

Note

*1 Measured on wafer prior to packaging.

*2 Scaled from PCM data.

*3 Pulse width 100 μsec , Duty Cycle 10%.

*4 Measured in the IE08220P test board amplifier circuit, under LTE 10MHz, PAR7.5dB @0.01% probability on CCDF.

*5 Measured in the IE08220P test board amplifier circuit. No damage at all phase angles.

*6 Psat is defined as $\Delta P_{out}/\Delta P_{in} < 0.1$, where ΔP_{in} is increased input power, ΔP_{out} is increased output power.

Typical Pulsed Signal Performance

(Tc=25°C, Measured in the IE08220P test board amplifier circuit)

Peak Power, Drain Efficiency vs. Frequency

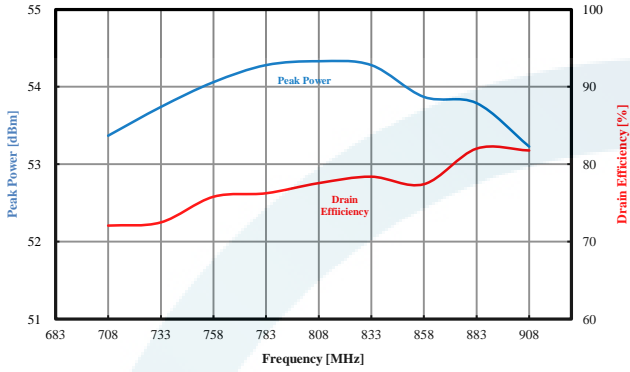

Pulsed Power Gain, Drain Efficiency vs. Output Power

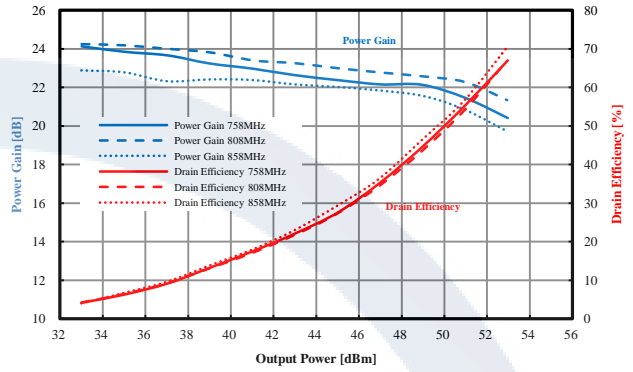

V_{DS} = 48V, I_{DQ} = 1000mA, Pulse Width = 100µsec, Duty Cycle = 10%

Typical LTE Signal Performance

(Tc=25°C, Measured in the IE08220P test board amplifier circuit)

LTE Power Gain, Drain Efficiency, ACLR, PARC vs. Frequency

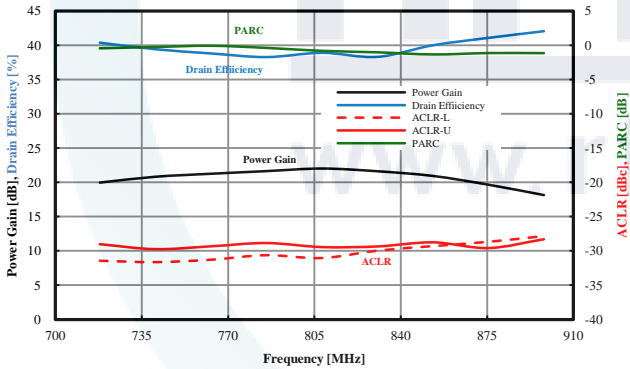

Power Gain, Drain Efficiency vs. Output Power

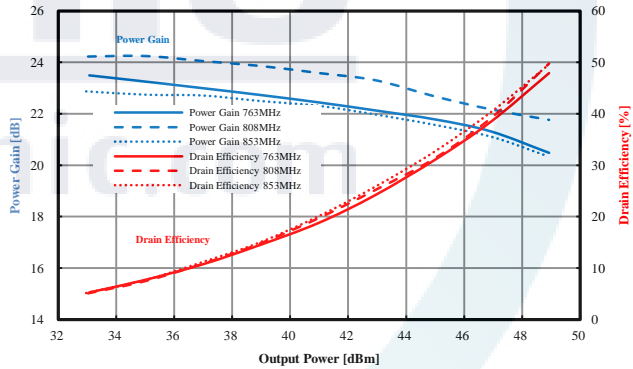

PARC, ACLR vs. Output Power

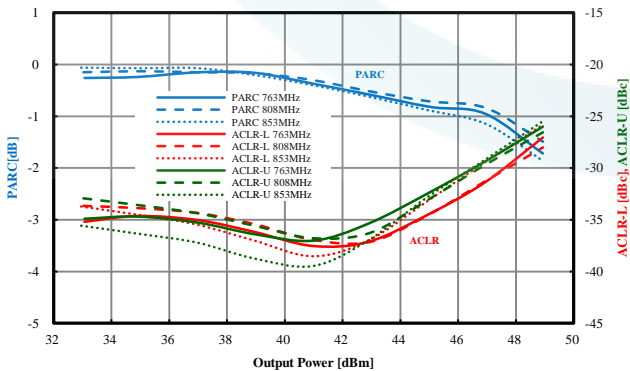

P_{AVG} = 47dBm, V_{DS} = 48V, I_{DQ} = 1000mA
 LTE 10MHz BW, PAPR=7.5dB @ 0.01% Probability on CCDF

Typical 2-tone Intermodulation Imbalance Performance

(Tc=25 °C, Measured in the IE08220P test board amplifier circuit)

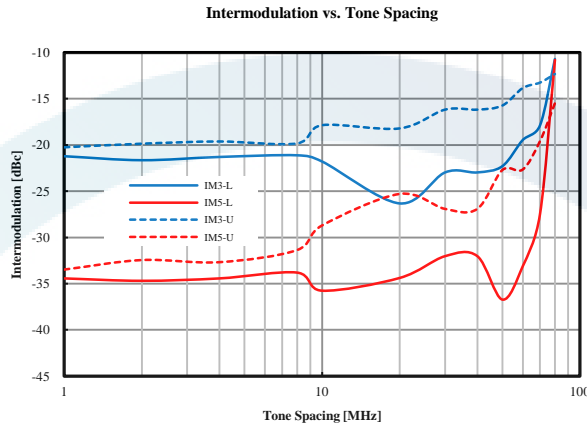

2-tone Power = 51.4dBm, V_{DS} = 48V, I_{DQ} = 1000mA

Typical Small Signal Performance

(Tc=25 °C, Measured in the IE08220P test board amplifier circuit)

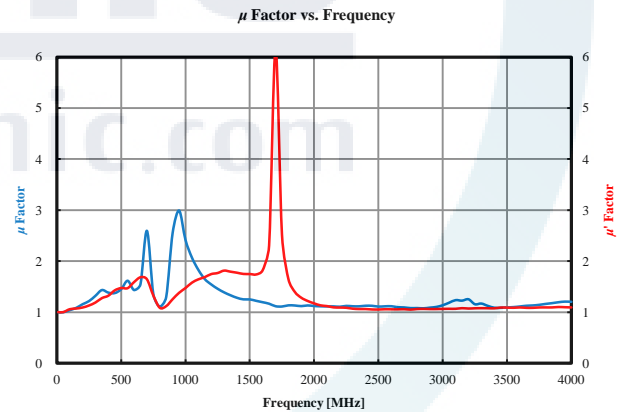
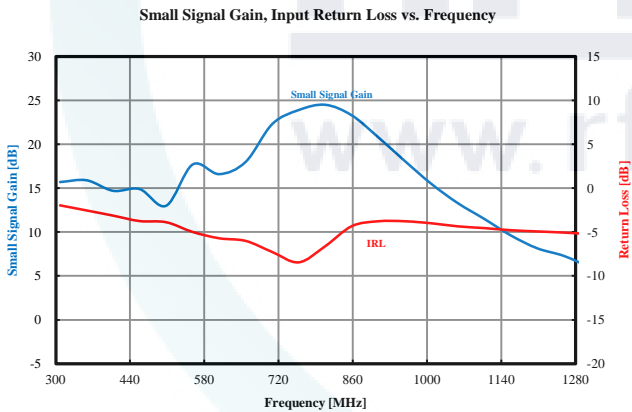

P_{IN} = 0dBm, V_{DS} = 48V, I_{DQ} = 1000mA

Test Board Component Layout

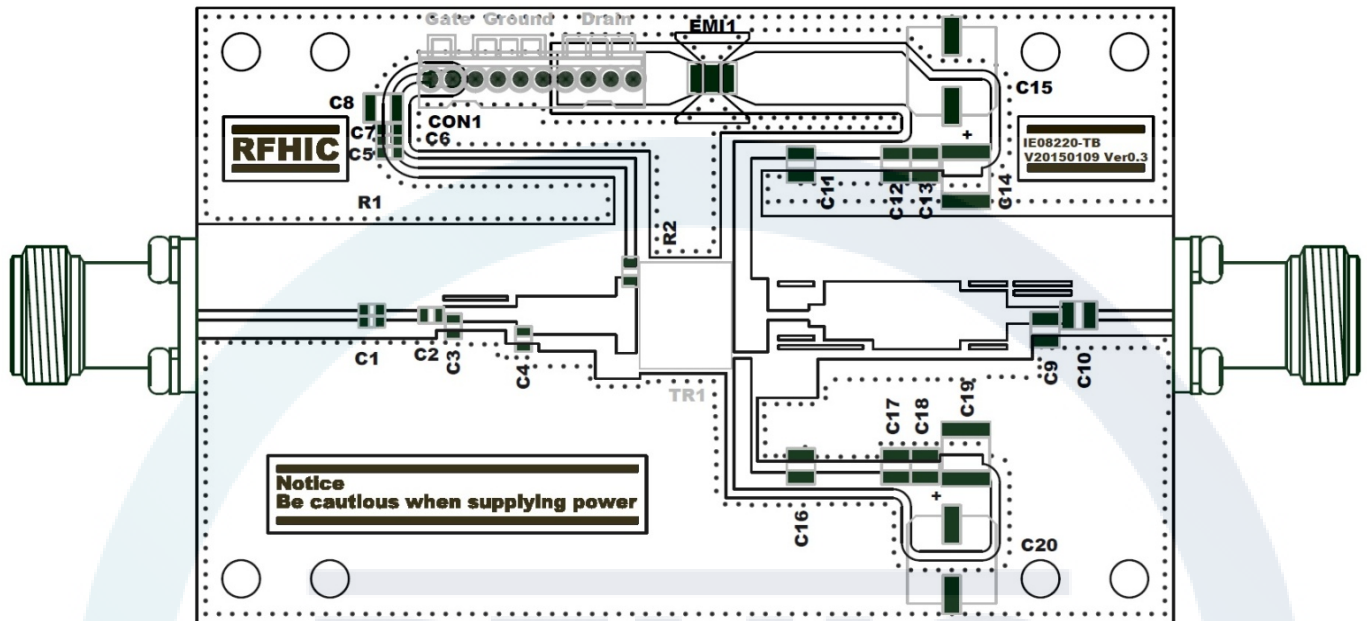

Part	Description	Part Number	Manufacturer
R1,R2	10 ohm Chip Resistor	MCR10EZHZJ100	ROHM
C1	6.8pF High Q Capacitor	201CHA6R8CSLE	TEMEX
C2	8.2pF High Q Capacitor	201CHA8R2CSLE	TEMEX
C3	6.2pF High Q Capacitor	201CHA6R2CSLE	TEMEX
C4	5.6pF High Q Capacitor	201CHA5R6CSLE	TEMEX
C5	100pF Chip Capacitor	GRM188R71H101KA01D	MURATA
C6	10nF Chip Capacitor	GRM188R71H103KA01D	MURATA
C7	100nF Chip Capacitor	GRM188R71H104KA93D	MURATA
C8	Polymer Capacitor	TCJB476M010R0070	AVX
C9	0.5pF High Q Capacitor	501CHB0R5BSLE	TEMEX
C10	12pF High Q Capacitor	501CHB120JSLE	TEMEX
C11	27pF High Q Capacitor	501CHB270JSLE	TEMEX
C12	100pF High Q Capacitor	501CHB101JSLE	TEMEX
C13	1nF High Q Capacitor	501CHB102JSLE	TEMEX
C14	10uF MLCC	RS80R2A106M	MARUWA
C15	33uF Aluminum Capacitor	BDS100VC33MJ10TP	SAMYOUNG
C16,C17,C18,C19,C20	-	-	-
EMI	EMI FILTER	CTH32R102S20A-TM	MARUWA
CON1	DC Connector	5045-10	MOLEX
PCB	$\epsilon_r=3.48 \pm 0.05$, 0.020" (0.508mm)	RO4350B	ROGERS Corp.
TR	220W GaN Transistor	IE08220P	RFHIC

Package Dimensions (Type: NS-AS01)

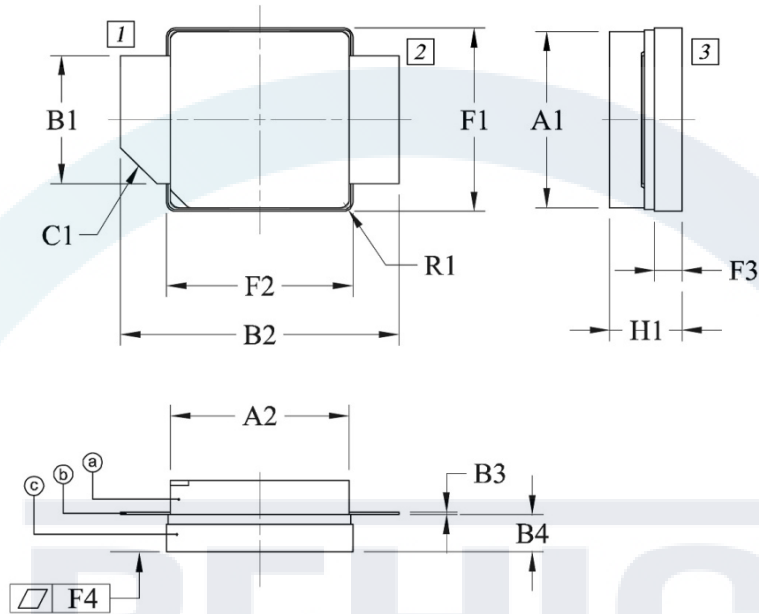

Pin Description	
Pin No	Function
1	Gate
2	Drain
3	Source

- Ⓐ- Lid
- Ⓑ- Lead Frame
- Ⓒ- Flange

Dim.	INCH			MILLIMETER		
	MIN	TYP	MAX	MIN	TYP	MAX
A1	.380	.384	.390	9.65	9.75	9.90
A2	.380	.384	.390	9.65	9.75	9.90
B1	.274	.280	.285	6.97	7.10	7.23
B2	.579	.598	.618	14.70	15.20	15.70
B3	.004	.005	.007	0.10	0.13	0.18
B4	.080	.085	.090	2.03	2.15	2.28
C1 (Chamfer)	.075	.079	.083	1.90	2.00	2.10
F1	.395	.400	.405	10.03	10.16	10.29
F2	.395	.400	.405	10.03	10.16	10.29
F3	.054	.059	.064	1.37	1.50	1.63
F4	-	.001	-	-	0.03	-
H1	.148	.159	.167	3.75	4.05	4.25
L1	-	-	-	-	-	-
L2	-	-	-	-	-	-
R1 (Radius)	.016	.020	.024	0.40	0.50	0.60

Revision History

Part Number	Release Date	Version	Description	Data Sheet Status
IE08220P	March, 2016	1.0	Modified Thermal Characteristics	-



RFHIC Corporation reserves the right to make changes to any products herein or to discontinue any product at any time without notice. While product specifications have been thoroughly examined for reliability, RFHIC Corporation strongly recommends buyers to verify that the information they are using is accurate before ordering. RFHIC Corporation does not assume any liability for the suitability of its products for any particular purpose, and disclaims any and all liability, including without limitation consequential or incidental damages. RFHIC products are not intended for use in life support equipment or application where malfunction of the product can be expected to result in personal injury or death. Buyer uses or sells such products for any such unintended or unauthorized application, buyer shall indemnify, protect and hold RFHIC Corporation and its directors, officers, stockholders, employees, representatives and distributors harmless against any and all claims arising out of such unauthorized use. Sales, inquiries and support should be directed to the local authorized geographic distributor for RFHIC Corporation. For customers in the US, please contact the US Sales Team at +1-919-677-8780. For all other inquiries, please contact the International Sales Team at 82-31-8069-3036 or Korean Domestic Sales Team 82-31-8069-3034.