

Product Features

- 2520~2630MHz
- 316W Saturated Power @ 48V
- 50% Drain Efficiency @ 46dBm
- Internally Matched
- Asymmetrical Doherty GaN HEMT

Applications

- WiMAX, LTE, WCDMA
- Multi-Band, Multi-Mode
- Multi-Carrier
- High Efficiency, Doherty Amplifier

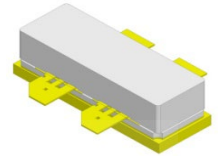

Package Type : RF18010DKR3

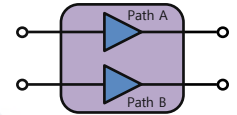

Typical Single-Carrier LTE Performance $(V_{DS}= +48V, T_C=25^\circ C, 50\Omega)$

Frequency [MHz]	Peak Power	Average Power ^{*1}			
	Power [W]	Power [W]	Gain [dB]	Drain Efficiency [%]	ACLR [dBc]
2520.0	328.1	40	14.5	49.4	-25.9
2575.0	333.4	40	14.4	50.8	-26.6
2630.0	322.1	40	14.1	49.6	-29.3

Note

*1 Measured in the ID25275WD Doherty test board amplifier circuit, under LTE 10MHz, PAR 7.5dB @0.01% probability on CCDF

Absolute Maximum Ratings

Rating	Symbol	Value	Unit	Condition
Drain to Source Voltage	V_{DSS}	150	V	$T_C=25^\circ C$
Gate to Source Voltage	V_{GS}	-10, +2	V	$T_C=25^\circ C$
Operating Voltage	V_{DD}	52	V_{DC}	
Storage Temperature	T_{STG}	-65, +150	$^\circ C$	
Case Operating Temperature	T_C	-40, +150	$^\circ C$	
Operating Junction Temperature ^{*1}	T_J	225	$^\circ C$	
Soldering Temperature ^{*2}	T_S	245	$^\circ C$	

Note

*1 Continuous use at maximum temperature will affect MTTF.

*2 Refer to the Application Note(AN-002) on soldering - "Solder Condition for RFHIC's GaN Device"

Thermal Characteristics

Rating	Symbol	Value	Unit	Condition
Thermal Resistance, Junction to Case	$R_{\theta JC}$	2.14 ^{*1}	$^\circ C/W$	$T_C=85^\circ C$

Note

*1 Measured for the ID25275WD at dissipation power is 65W.

Electrical Characteristics ($T_c=25^\circ\text{C}$ unless otherwise noted)

Characteristics	Conditions	Symbol	Min	Typ	Max	Unit
DC Characteristics - Path A (Carrier)^{*1}						
Maximum Forward Gate Current	$T_c = 25^\circ\text{C}$	I_{GMAX}	-	-	16	mA
Maximum Drain Current ^{*2}	$T_c = 25^\circ\text{C}$	I_{DMAX}	-	-	6.0	A
Power Dissipation	$T_c = 85^\circ\text{C}$	P_{DMAX}	-	-	65	W
Gate Threshold Voltage	$V_{DS} = 10\text{V}$	$V_{GS(TH)}$	-3.75	-3.00	-2.25	V_{DC}
	$I_D = 14.4\text{mA}$					
Gate Quiescent Voltage	$V_{DS} = 48\text{V}$	$V_{GS(Q)}$	-	-2.85	-	V_{DC}
	$I_D = 200\text{mA}$					
Drain-Source Breakdown Voltage	$V_{GS} = -8\text{V}$	V_{BR}	150	-	-	V
	$I_D = 14.4\text{mA}$					
Saturated Drain Current ^{*3}	$V_{DS} = 6\text{V}$	I_{DS}	12.0	14.4	-	A
	$V_{GS} = 2\text{V}$					
Gate Leakage Current	$V_{GS} = -8\text{V}$	$I_{GLKG150}$	-3.3	-	-	mA
	$V_{DS} = 150\text{V}$					
Drain Leakage Current	$V_{GS} = -8\text{V}$	$I_{DLKG150}$	-	-	5.8	mA
	$V_{DS} = 150\text{V}$					
DC Characteristics - Path B (Peaking)^{*1}						
Maximum Forward Gate Current	$T_c = 25^\circ\text{C}$	I_{GMAX}	-	-	24	mA
Maximum Drain Current ^{*2}	$T_c = 25^\circ\text{C}$	I_{DMAX}	-	-	9.0	A
Power Dissipation	$T_c = 85^\circ\text{C}$	P_{DMAX}	-	-	80.0	W
Gate Threshold Voltage	$V_{DS} = 10\text{V}$	$V_{GS(TH)}$	-3.75	-3.00	-2.25	V_{DC}
	$I_D = 21.6\text{mA}$					
Gate Quiescent Voltage	$V_{DS} = 48\text{V}$	$V_{GS(Q)}$	-	-2.700	-	V_{DC}
	$I_D = 200\text{mA}$					
Drain-Source Breakdown Voltage	$V_{GS} = -8\text{V}$	V_{BR}	150	-	-	V
	$I_D = 21.6\text{mA}$					
Saturated Drain Current ^{*3}	$V_{DS} = 6\text{V}$	I_{DS}	18.0	21.6	-	A
	$V_{GS} = 2\text{V}$					
Gate Leakage Current	$V_{GS} = -8\text{V}$	$I_{GLKG150}$	-4.5	-	-	mA
	$V_{DS} = 150\text{V}$					
Drain Leakage Current	$V_{GS} = -8\text{V}$	$I_{DLKG150}$	-	-	5.8	mA
	$V_{DS} = 150\text{V}$					

Note

*1 Measured on wafer prior to packaging.

*2 Current Limit for long term, reliable operation

*3 Scaled from PCM data.

Characteristics	Conditions	Symbol	Min	Typ	Max	Unit
RF Characteristics (F=2575MHz unless otherwise noted)						
Saturated Output Power ^{*1,4}	V_{DS} = 48V	P _{SAT}	200	316	-	W
	I_{DQ} = 200mA					
Modulated Gain ^{*2}	V_{DS} = 48V	G _{BR}	13.0	14.0	-	dB
	I_{DQ} = 200mA					
	P_{OUT} = 46dBm					
LTE Linearity ^{*2}	V_{DS} = 48V	ACLR	-	-25.0	-23.0	dBc
	I_{DQ} = 200mA					
	P_{OUT} = 46dBm					
Modulated Drain Efficiency ^{*2}	V_{DS} = 48V	η	43	50	-	%
	I_{DQ} = 200mA					
	P_{OUT} = 46dBm					
Output Mismatch Stress ^{*1,3}	V_{DS} = 48V	VSWR	-	-	10:1	ψ
	I_{DQ} = 200mA					
	P_{OUT} = P_{SAT} Pulsed					

Note

*1 Pulse width 100μsec, Duty Cycle 10%.

*2 Measured in the ID25275WD Doherty test board amplifier circuit, under LTE 10MHz, PAR7.5dB @0.01% probability on CCDF.

*3 Measured in the ID25275WD Doherty test board amplifier circuit. No damage at all phase angles.

*4 Psat is defined as $\Delta P_{out}/\Delta P_{in} < 0.1$, where ΔP_{in} is increased input power, ΔP_{out} is increased output power.



Typical Pulsed Signal Performance (Tc=25°C, Measured in the ID25275WD test board amplifier circuit)

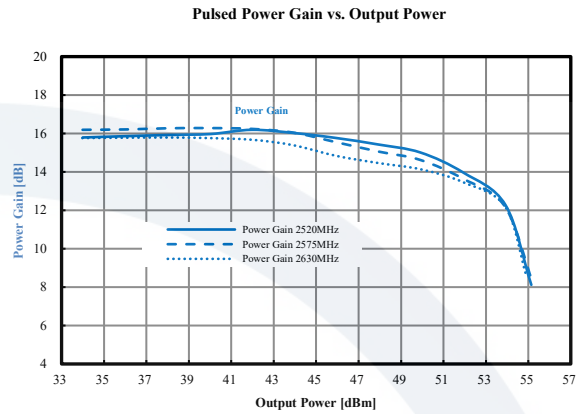
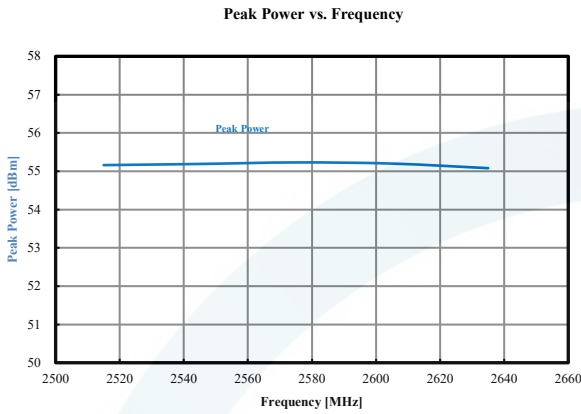

$V_{DS} = 48V$, $I_{DQ(C)} = 200mA$, $V_{GS(P)} = -5.5V$, Pulse Width = 100µsec, Duty Cycle = 10%

Typical LTE Signal Performance (Tc=25°C, Measured in the ID25275WD test board amplifier circuit)

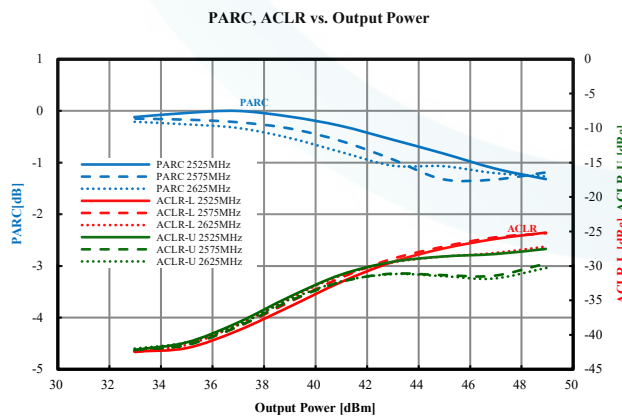
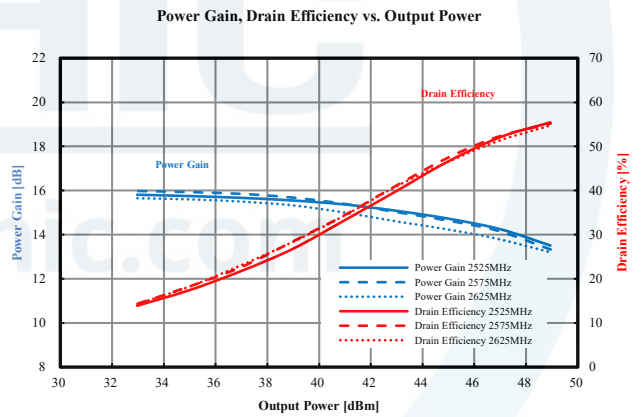
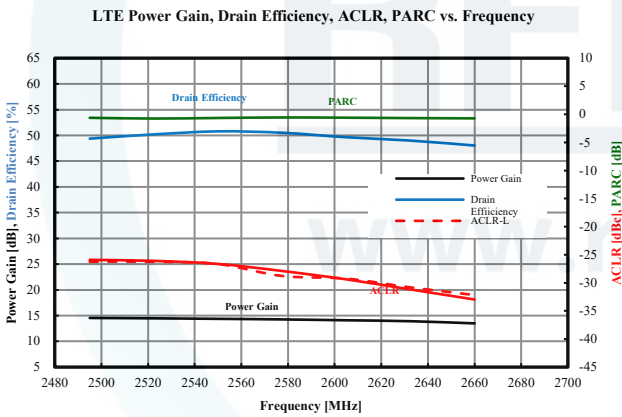

$P_{AVG} = 46dBm$, $V_{DS} = 48V$, $I_{DQ(C)} = 200mA$, $V_{GS(P)} = -5.5V$
 LTE 10MHz BW, PAPR=7.5dB @ 0.01% Probability on CCDF

Typical 2-tone Intermodulation Imbalance Performance

(Tc=25°C, Measured in the ID25275WD Doherty test board amplifier circuit)

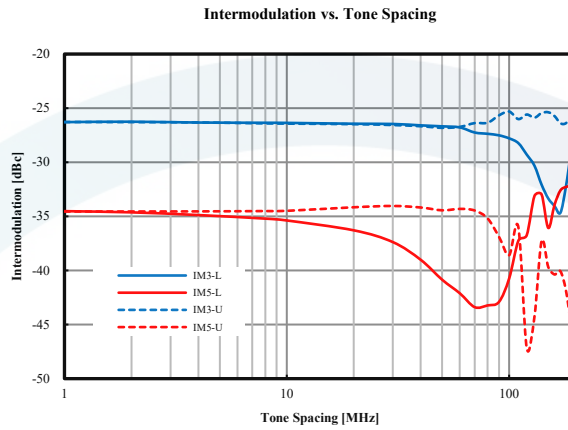

2-tone Power = 46dBm, $V_{DS} = 48V$, $I_{DQ(C)} = 200mA$, $V_{GS(P)} = -5.5V$

Typical Small Signal Performance

(Tc=25°C, Measured in the ID25275WD Doherty test board amplifier circuit)

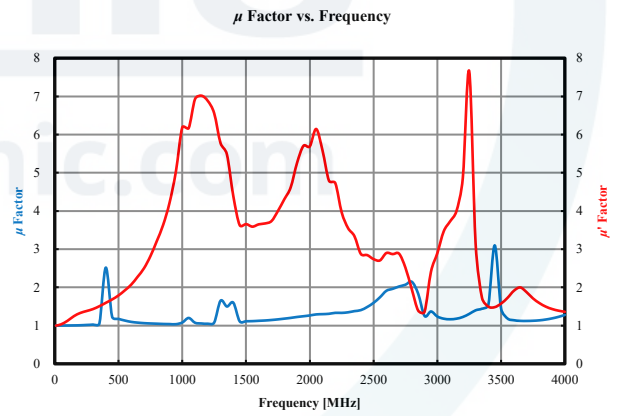
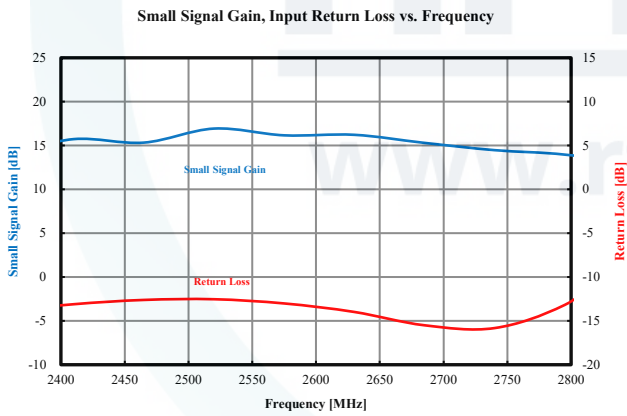

$P_{IN} = 0dBm$, $V_{DS} = 48V$, $I_{DQ} = 200mA$, $V_{GS(P)} = -5.5V$

Test Board Component Layout

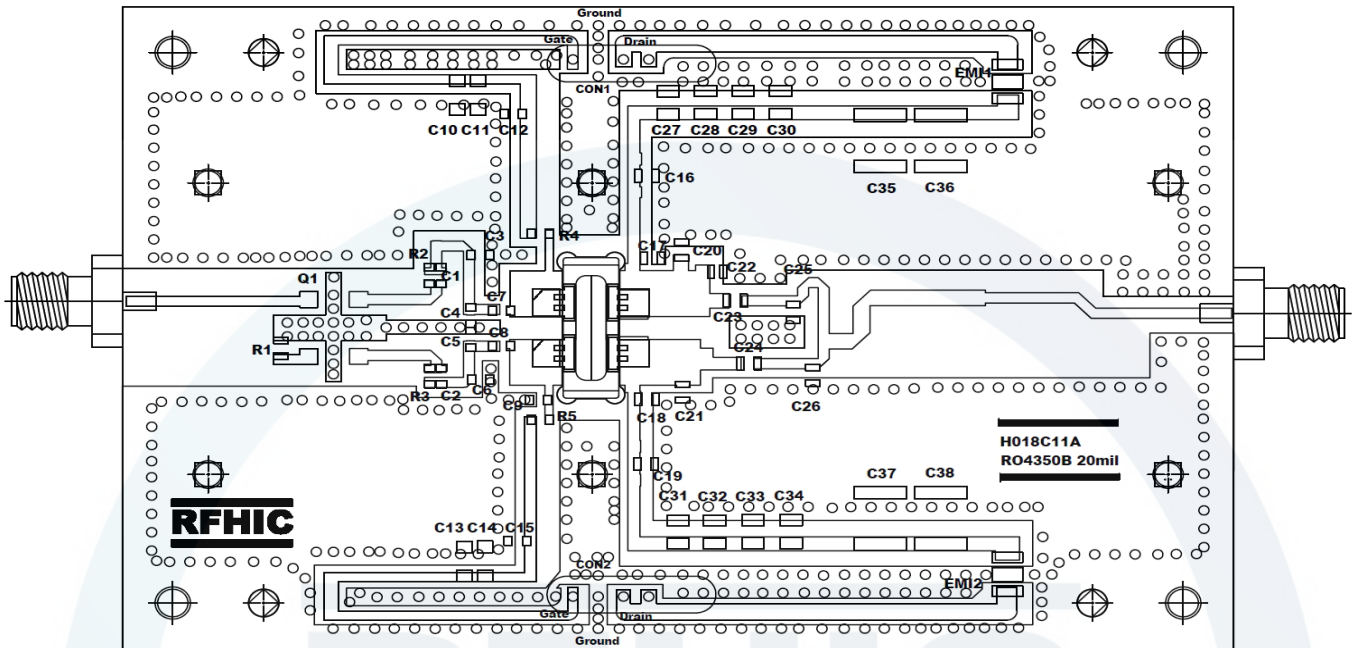

Part	Description	Part Number	Manufacturer
Q1	Hybrid coupler	1P603AS	ANAREN
R1	50 ohm Power Resistor	S1020A	RN2
R2, R3	18 ohm Chip Resistor	MCR03EZP5J180	ROHM
R4, R5	10 ohm Chip Resistor	MCR03EZPJ100	ROHM
C1, C2, C7, C8, C12 C15, C16, C19, C24	8.2 pF High Q Capacitor	GQM1875C2E8R2CB12D. 1608. 250V	MURATA
C3, C26	0.5 pF High Q Capacitor	GQM1875C2ER50BB12D. 1608. 250V	MURATA
C4, C5, C9, C21	1.0 pF High Q Capacitor	GQM1875C2E1R0BB12D. 1608. 250V	MURATA
C6, C22	0.8 pF High Q Capacitor	GQM1875C2ER75BB12D. 1608. 250V	MURATA
C10, C11, C13, C14 C27, C28, C29, C30 C31, C32, C33, C34	2.2uF	GRM32ER72A225KA.3225.100V	MURATA
C17, C18	2.2 pF High Q Capacitor	GQM1875C2E2R2BB12D. 1608. 250V	MURATA
C20	1.2 pF High Q Capacitor	GQM1875C2E1R2BB12D. 1608. 250V	MURATA
C23	3.9 pF High Q Capacitor	GQM1875C2E3R9BB12D. 1608. 250V	MURATA
C25	1.5 pF High Q Capacitor	GQM1875C2E1R5BB12D. 1608. 250V	MURATA
C35, C36, C37, C38	22uF MLCC	RS80R2A226M. 5750. 100V	MARUWA
EMI1, EMI2	EMI FILTER	CTH32R102S20A-TM	MARUWA
CON1, CON2	DC Connector, 4 pin	5267-04A	MOLEX
PCB	$\epsilon_r=3.66 \pm 0.05$, 0.020" (0.508mm)	RO4350B	ROGERS Corp.
TR1	275W GaN Transistor	ID25275WD	RFHIC

Package Dimensions (Type:RF18010DKR3)

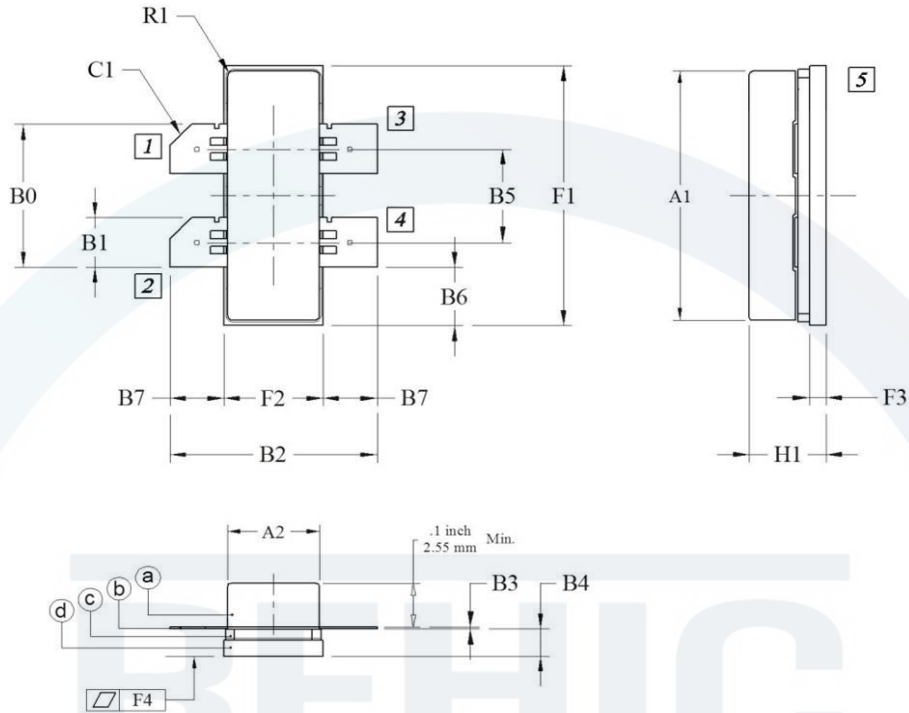

Pin Description	
Pin No	Function
1	Path A Gate
2	Path B Gate
3	Path A Drain
4	Path B Drain
5	Source

- Ⓐ- Lid
- Ⓑ- Lead Frame
- Ⓒ- Ceramic Ring
- Ⓓ- Flange

Dim.	INCH			MILLIMETER		
	MIN	TYP	MAX	MIN	TYP	MAX
A1	.573	.579	.585	14.55	14.70	14.85
A2	.195	.201	.207	4.95	5.10	5.25
B0	.325	.331	.337	8.25	8.40	8.55
B1	.109	.114	.119	2.775	2.900	3.025
B2	.432	.453	.473	10.98	11.50	12.03
B3	.003	.005	.007	0.075	0.125	0.175
B4	.057	.062	.067	1.455	1.580	1.705
B5	.211	.217	.222	5.35	5.50	5.65
B6	-	.136	-	-	3.45	-
B7	-	.118	-	-	3.00	-
C1 (Chamfer)	.034	.039	.044	0.875	1.000	1.125
F1	.597	.602	.607	15.175	15.300	15.425
F2	.212	.217	.221	5.375	5.500	5.625
F3	.032	.036	.040	0.82	0.92	1.02
F4	-	.002	-	-	0.05	-
H1	.157	.167	.177	4.00	4.25	4.50
R1 (Radius)	.008	.012	.016	0.20	0.30	0.40

Lid Epoxy Tolerance & Package Alignment

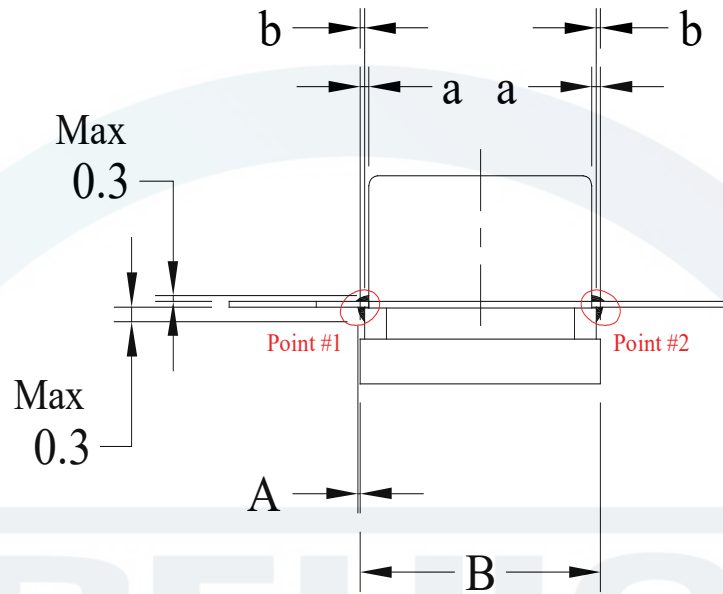

Inspection Items	Package Area	Inspection Method
Point#1 (Below the leadframe)	Gate Lead Frame	A: Gate epoxy overflow If 'A' exceeds than 200um or 'A+B' exceeds maximum width of the basemetal, then the product should be rejected..
Point#2 (Below the leadframe)	Drain Lead Frame	B : Package base width If the epoxy overflows the base (B) of package, then the product should be rejected.
a	Ceramic Lid to Basemetal	$a \geq 0$ (a:Distance between ceramic lid edge and basemetal edge)
b	Ceramic Ring to Basemetal	$b \geq 0$ (b:Distance between ceramic ring edge and basemetal edge)

Revision History

Part Number	Release Date	Version	Description	Data Sheet Status
ID25275WD	June, 2021	1.0	Initial release of datasheet	



RFHIC Corporation reserves the right to make changes to any products herein or to discontinue any product at any time without notice. While product specifications have been thoroughly examined for reliability, RFHIC Corporation strongly recommends buyers to verify that the information they are using is accurate before ordering. RFHIC Corporation does not assume any liability for the suitability of its products for any particular purpose, and disclaims any and all liability, including without limitation consequential or incidental damages. RFHIC products are not intended for use in life support equipment or application where malfunction of the product can be expected to result in personal injury or death. Buyer uses or sells such products for any such unintended or unauthorized application, buyer shall indemnify, protect and hold RFHIC Corporation and its directors, officers, stockholders, employees, representatives and distributors harmless against any and all claims arising out of such unauthorized use.

Sales, inquiries and support should be directed to the local authorized geographic distributor for RFHIC Corporation. For customers in the US, please contact the US Sales Team at 919-677-8780. For all other inquiries, please contact the International Sales Team at 82-31-8069-3000.